

B-B  
1:2

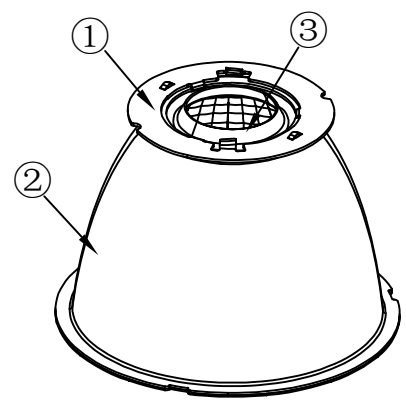

A - A

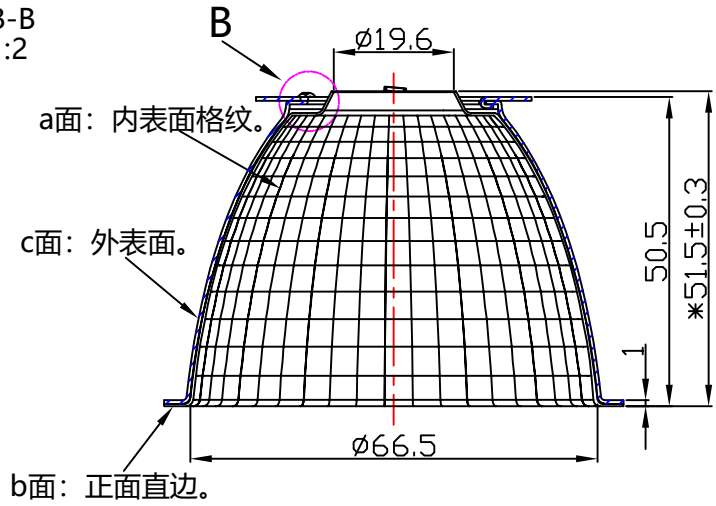
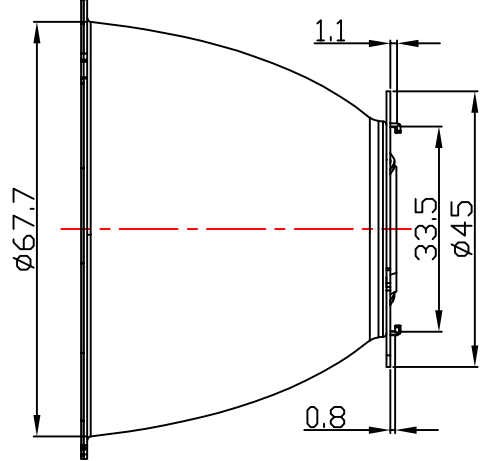
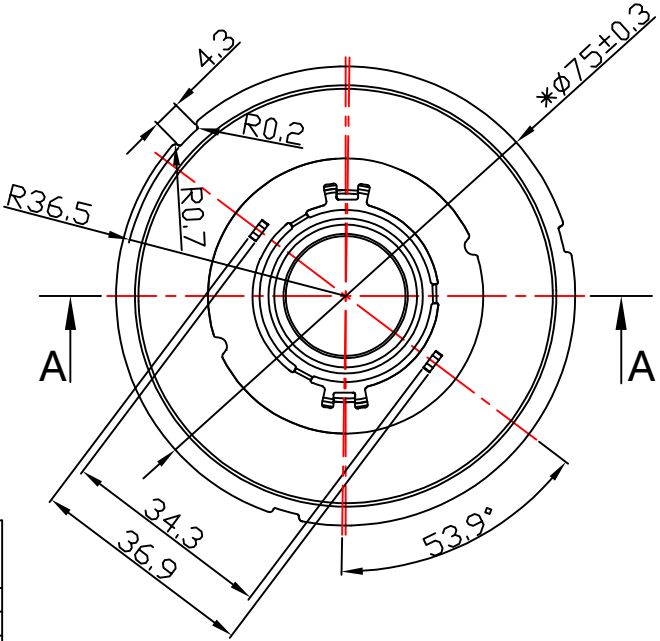

Light Source	LUMILEDS 1208
Plastic Holder	92.70.411.00
Metal Adaptor	
Design Angle	$38^\circ \pm 3^\circ$
Measured Angle	$39.4^\circ$
Efficiency	

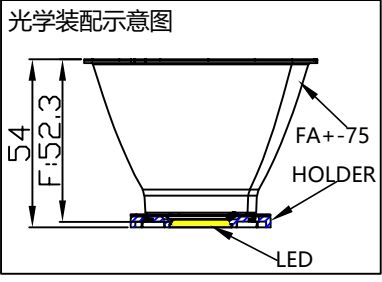

Technical requirements:  
 1.\*\*\*KEY CONTROL DIMENSION.  
 2.Tolerances not noted are in accordance with the tolerance table.  
 3.unmarked rounded corners Press for 3D.  
 4.Surface without imprint, black spots, cracks, wrinkles and other poor.

PRODUCT BOM				
NO.	PRODUCT NAME	PRODUCT CODE	QUANTITY	MATERIAL/FINISH
①	2-2641-L卡扣	97.77.073.00	1	T=0.6mm SUS301
②	2-2476-A	94.02.2476.000	1	T=0.6mm 1070AL/Andoizing
③	2-2520-A	94.02.2520.000	1	T=0.4mm High reflectivity aluminum(Mirror surface)

标记 MARK	处数 NO.OF MODIF	更改内容 MODIFICATIONS	签名 SIGNED BY	更改日期 MODIF. DATE
设计 DESIGNER	制图 DRAWN BY	审核 CHECKED BY	比例 SCALE	1:1
工艺 TECHNICIAN	日期 DATE(DD-MM-YYYY)	13-05-2022	视角 1st ANGLE PROJECTION	
批准 APPROVED BY	日期 DATE(DD-MM-YYYY)	13-05-2022	页数 PAGE	SHEET 1 OF 1

DIMENSION TOLERANCE TABLE (UNLESS OTHERWISE STATED) (UNIT:MM)						
> 0-5	> 5-30	> 30-90	> 90-150	> 150-250	> 250-400	> 400-700
±0.15	±0.2	±0.4	±0.5	±0.8	±1.5	±2

PUNCH TOLERANCE TABLE (UNLESS OTHERWISE STATED) (ANGLE)				
> 0-10	> 10-50	> 50-120	> 120-250	> 250-360
±1°	±0.5°	±0.3°	±0.2°	±0.166°

**Nata**® 版本  
VERSIONS  
K

产品编码 PRODUCT CODE	91.02.2645.000
产品名称 PRODUCT NAME	2-2645-L
客户代号 CUSTOMER ID	NT
客户编号 CUSTOMER CODE	FA+-75-38D

产品图  
PRODUCT DRAWING

单位  
UNIT  
mm